

QUICK TIPS FOR INSTALLING HORIZONTAL VINYL SIDING

For best results, use certified vinyl siding. The VSI Vinyl Siding Installation Manual, found at vinylsiding.org, provides more information about how to install vinyl siding and accessories. Please see the manufacturer's instructions.

Visit vinylsiding.org for more information.



TOOLS



STANDARD ACCESSORIES

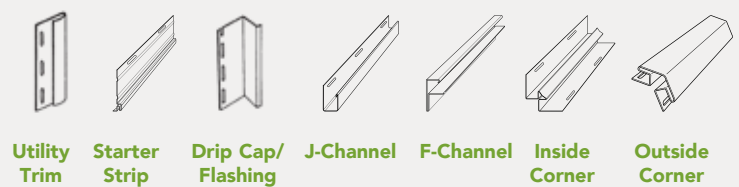

* All accessories should be fastened 8"-12" max on center. Do not drive the head of the fastener tightly against the accessory nail hem. Allow approximately 1/32" (0.8mm) clearance (the thickness of a dime) between the fastener head and the vinyl.

TIPS FOR A SUCCESSFUL INSTALL

CUTTING VINYL SIDING

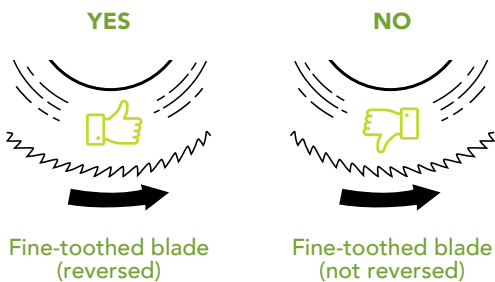

(OR USE A VINYL SIDING BLADE)

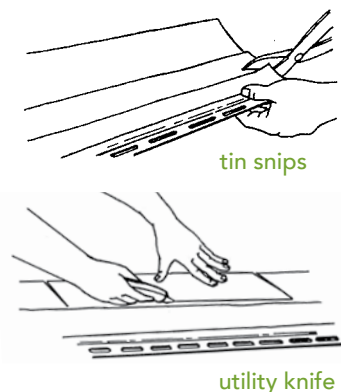

INSTALLING VINYL ACCESSORIES

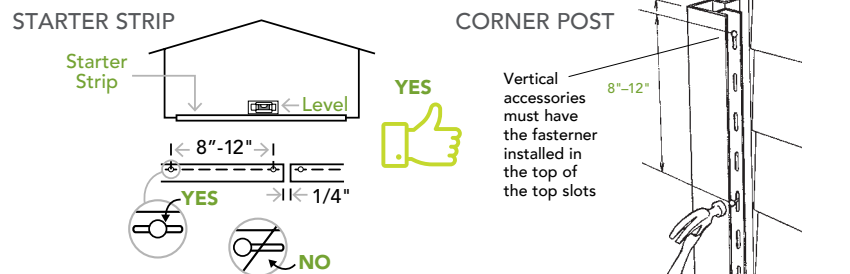

DOORS AND WINDOWS

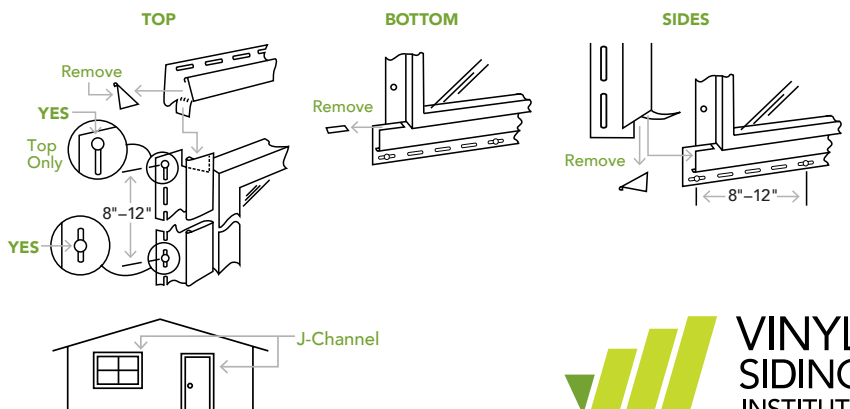

NAILING: Vertical Accessories or Siding

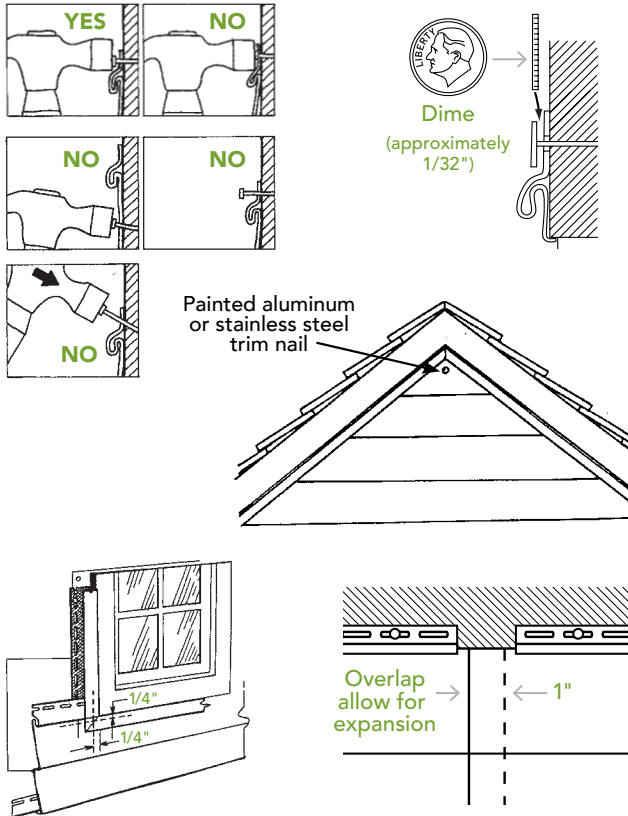

INSTALLING PANELS

1. Minimum fastener length must be sufficient to penetrate sheathing other nailable substrate and framing a total of a minimum of 1 1/4" (32mm) or in accordance with the manufacturer's installation instructions.
2. Do not drive the nail tight against the nail hem.
3. Leave approximately 1/32" clearance (about the thickness of a dime) between the fastener head and the nail hem.
4. Make sure that the panels and accessories move freely when fastened.
5. Leave 1/4" clearance inside all receiving channels at all openings and stops for expansion and contraction. Increase to 3/8" (9.5mm) when installing in temperatures below 40° F.
6. When panels overlap, make sure they overlap by 1" on the face of the panel.
7. Overlap panels away from entrances and away from the point of greatest traffic.
8. Do not face-nail through siding, except for the one nail needed to finish at top of a gable.

LOCKING PANELS

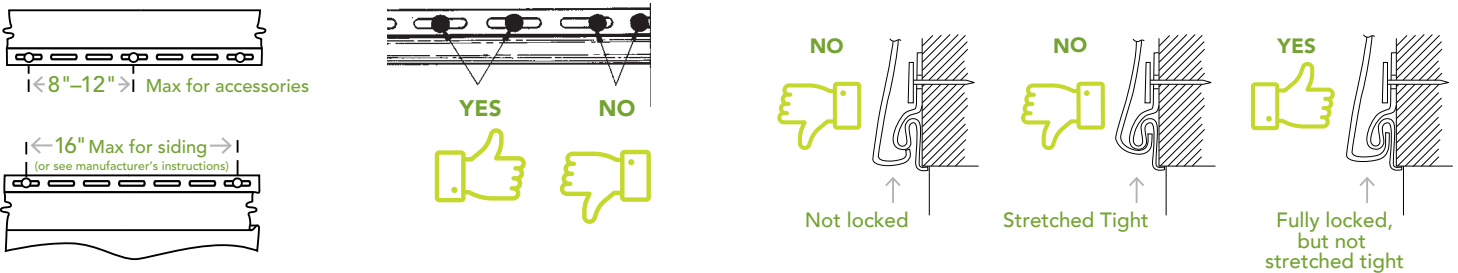

PANEL ALIGNMENT

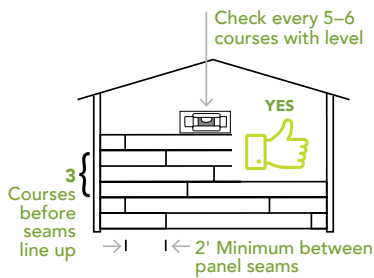

FINISHING: Last Course in Eave Options

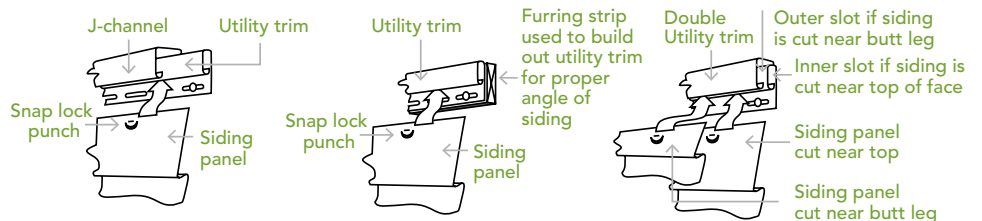

*Snap lock punches should be about 6" on center.